

Can rapid pressure decrease induced by supercavitation efficiently eradicate *Legionella Pneumophila* bacteria?

Andrej Šarc

Laboratory for Water and Turbine Machines, Faculty of Mechanical Engineering
University of Ljubljana
Aškerčeva 6, 1000 Ljubljana, Slovenia
E-mail: andrejsarc@gmail.com
Phone: +386 31 419 005

Martina Oder

Biomedical Research Group, Faculty of Health sciences, University of Ljubljana,
Zdravstvena pot 5, 1000 Ljubljana, Slovenia
E-mail: martina.oder@zf.uni-lj.si
Phone: +386 1 3001 182

Matevž Dular (corresponding author)

Laboratory for Water and Turbine Machines, Faculty of Mechanical Engineering
University of Ljubljana
Aškerčeva 6, 1000 Ljubljana, Slovenia
E-mail: matevz.dular@fs.uni-lj.si
Phone: +386 1 4771 453

Abstract

The presence of *Legionella Pneumophila* bacteria in engineered water systems can pose a significant health risk. Current prevention and outbreak treatments are cost and environmentally ineffective. Moreover they do not prevent rapid bacteria recolonization.

Although cavitation was already suggested as a possible water treatment technique a systematic study has not yet been performed.

In the present experimental campaign we set out to evaluate the efficiency of removal of *Legionella pneumophila* by three types of cavitation – the most commonly used acoustic cavitation, the aggressive developed hydrodynamic cavitation, and the supercavitation.

We show that it is probably not the pressure peaks or the high local temperatures that cause the eradication of the bacteria, but the rapid pressure decrease which was initiated in supercavitating flow regime.

Results of the study show promising ground for further optimization of a methodology for *Legionella pneumophila* removal by cavitation.

Key words: Cavitation, *Legionella pneumophila* bacteria, supercavitation, developed hydrodynamic cavitation, ultrasonic cavitation

1 Introduction

1.1 *Legionella Pneumophila*

Legionella pneumophila is a thin, aerobic, pleomorphic, flagellated, non-spore forming, Gram-negative

bacteria of the genus *Legionella*. It is a rod shaped (Fig. 1), 2 to 20 μm long and 0.3 to 0.9 μm wide [1]. It is a microphilic and aerobic bacteria, has a respiratory metabolism and has a single polar flagellum [2].



Figure 1: Transmission electron micrograph of *Legionella Pneumophila* (courtesy of Public Health Image Library [3])

Legionella pneumophila are wide spread in all natural fresh water sources in predominantly low concentrations. The bacteria has also frequently been observed in engineered water systems such as warm water distributing systems, cooling towers, humidifiers and fountains [4-6]. It multiplies at temperatures between 20 and 43 $^{\circ}\text{C}$, with an optimal growth temperature of 35 $^{\circ}\text{C}$ [7-9].

In low concentrations *Legionella pneumophila* does not represent a significant risk for the health of humans, however the multiplication of the bacteria in water systems poses a potential human health risk wherever aerosolisation can occur – for example in cooling towers, air-conditioning systems and showers [10].

Legionellosis is the name for a group of illnesses associated with legionella bacteria which are contracted by breathing in water droplets (aerosoles) that contain *Legionella pneumophila*. It is responsible for two types of illnesses [11, 12]. Legionnaires' disease is a potentially fatal, bacterial pneumonia infection that is contracted by 2 to 5 % of those exposed. The average mortality rate is accepted to be anything between 15 and 20 % of people infected [13]. Pontiac fever is a more common, flu like illness which usually last up to five days [14].

The illnesses occur more frequently in men than women (due to typical occupations, lifestyles and possibly lungs size). It usually affects middle-aged or elderly people and individuals with suppressed immune systems. Legionnaires' disease is very uncommon under the age of 20 and whilst children can catch the disease it is very rare [1, 15]. Concerning is also the fact that the number of infections is increasing over the last years, from 4.1 reported cases of Legionnaires' disease per million population in 1993 to 11.8 reported cases per million in 2008 [16].

Numerous measures can be adopted to create water systems in the built environment hostile to the multiplication of *Legionella pneumophila*. Wherever possible, temperature should be controlled by ensuring that cold water is stored below 20 $^{\circ}\text{C}$ and that it is distributed to all outlets within two minutes of opening the tap. Similarly hot water should be stored above 60 $^{\circ}\text{C}$ and distributed and supplied to all outlets at a temperature above 50 $^{\circ}\text{C}$ within 1 minute of operation. Needless to say, stagnation of water in pipes should be prevented [17].

When *Legionella pneumophilla* outbreak occurs or a potential outbreak is foreseen, thermal shocks are

most traditionally employed. Here the temperature of the water in the system is raised above 60 – 70 °C for as much as 30 minutes, which destroys the *Legionella pneumophila*. [18] (Schulze-Röbbecke et al. 1987). This method can prove ineffective for long-term *Legionella pneumophila* infestation management and it also can damage older pipes and create potential for scalding [19].

Another method is the shock chlorination disinfection which involves injecting chlorine into the water distribution system. Initial shock chlorination levels approach 50 ppm. A concern with this method is that chlorine decomposes rapidly at elevated water temperatures, and *Legionella pneumophila* recolonization can occur in as little as one to two weeks. The method has also proven highly corrosive to plumbing [20].

One of the more recent approaches is the copper-silver ionization. This disinfection method dissolves and distributes small amounts of copper and silver ions throughout water systems to eradicate bacteria. Installation of a continuous eradication metallic ion unit is required [21].

1.2 Cavitation

Lately studies of employing hydrodynamic cavitation for water treatment emerged in a variety of fields. For example for removal of pharmaceuticals [22-25], cyanobacteria and microalgae [26-28], for enhancement of biogas production from waste activated sludge [29] and even for eradication of some types of bacteria [30-32].

The existing methods of *Legionella pneumophila* removal have some disadvantages - energy efficiency, introduction of chemicals into the water system, poor long term disinfection and cost. Recently, due to its aggressive nature, cavitation was suggested as the possible mechanism for the removal of *Legionella pneumophila* [33]. The systematic studies are however scarce and researchers, in light of poor results, often resort to a combination of additives (for example TiO₂) and cavitation [34]. This leads to often encouraging but still partial results, which do not enable optimization of the process.

The term cavitation denotes the appearance of vapor bubbles in an initially homogeneous liquid. In contrast to boiling where evaporation is achieved by increase of the temperature, cavitation occurs due to the decrease of local pressure at an approximately constant temperature. In liquid flows, this phase change generally occurs due to local high velocities, which induce low pressures and is referred to as “hydrodynamic” cavitation. Yet, cavitation can also occur in a static liquid, when an oscillating pressure field is applied by means of, for example, ultrasonic piezo transducer. Such type of cavitation is known as “acoustic” or “ultrasonic” cavitation [35].

Further on the hydrodynamic cavitation is characterized by its general appearance and extent – one can distinct between attached steady cavitation, developed unsteady cavitation and supercavitation. Attached steady cavitation is of a lesser engineering importance. Developed cavitation commonly exhibits unsteady cavitation cloud shedding accompanied by generation of noise, vibration and extreme temperature and pressure pulsations. Supercavitating flow shows only one quasi steady vapor filled cavity, where larger disturbances in pressure and temperature are uncommon [35].

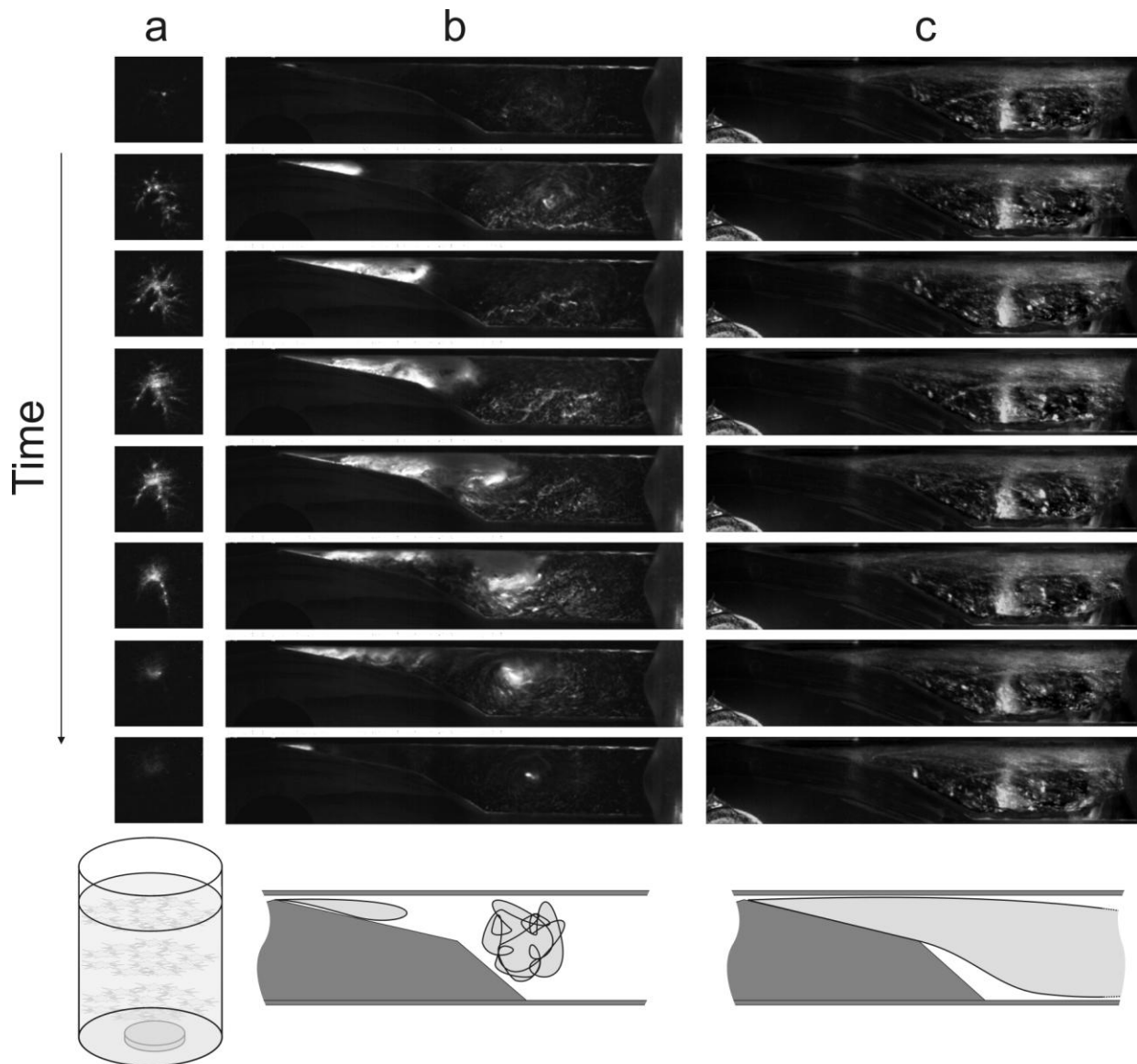

Figure 2: (a) Acoustic cavitation, (b) developed hydrodynamic cavitation and (c) supercavitation investigated in the present experimental campaign.

Effects of cavitation can be either positive or negative. While the negative effect include erosion, noise, and vibration, in the last years, cavitation is also being used in industrial processes (ultrasonic devices are most commonly used). Examples include: cleaning of surfaces, production of emulsions, electrolytic deposition and purification of water, removal of pharmaceuticals and bacteria eradication [35].

Each of the three, above mentioned, cavitation type influences the bacteria in a specific way. Also each one has its own advantages and drawbacks. In acoustic cavitation the vaporous voids appear due to the tension in the liquid produced by an ultrasonic transducer. The frequencies at which the transducer operates usually lie in the range from 20 kHz to 1.1 MHz. The bubbles do not grow to a large size and (at the highest power) only form small distinctive structures (Fig. 2a). The bubble collapses usually follow the driving frequency of the transducer, hence one can appreciate the very intense cavitation dynamics. Most commonly the high pressures and the temperatures, which occur at the bubble collapse

are mentioned as the driving mechanisms for water purification [36]. One of the drawbacks of the acoustic cavitation is that the bubbles appear only at antinodes of the standing waves in the vessel – some kind of mixing is therefore essential if one wants to sonicate the whole volume. Also acoustic cavitation has a low economic efficiency, as it is difficult to apply to a continuous (flowing) process. In addition the feasibility of scaling from laboratory to industrial size application is questionable [36].

In hydrodynamic cavitation the evaporation occurs due to the pressure drop in the region of an increased velocity (a narrow gap, obstacle etc.) The liquid medium is then "broken" at one or several points and "voids" appear, whose shape depends strongly on the structure of the flow. Generally speaking, there are two types of behavior observed in developed hydrodynamic cavitation domain: i) smaller cavities, which are rather short and thin; their lengths are fairly constant and the flow is on the whole stable and ii) the unstable cavities, which are thicker - an example is shown in Fig. 2b. Their lengths are variable because of the shedding of part of the cavities, entrained by the main flow. The shedding can be either random or periodic. The physics behind the shedding of the clouds bases on the fact that the minimum pressure occurs inside the cavity what initiates the curvature of the surrounding streamlines, which tend to be directed towards the cavity. Hence the cavity reattaches to the solid wall by splitting the surrounding liquid flow into two parts: i) the re-entrant jet which travels upstream, carrying a small quantity of the liquid to the inside the cavity, and ii) the outer flow which reattaches to the wall. Such a configuration cannot be steady, or else the cavity would be filled with liquid. Therefore, the jet from time to time strikes the front section of the cavity interface what leads to the separation of part of the cavity which is entrained downstream by the main flow. At the instant of shedding, a circulation arises around this vapor structure, which takes the form of a spanwise vortex. It is broken up into numerous smaller vapor structures such as bubbles or cavitating vortex filaments. A new cavity then develops and grows, and a new re-entrant jet forms. Meanwhile the separated cavity, which was entrained downstream by the main flow violently collapses as it enters a region of pressure recovery. The concentration of energy at collapse results in high pressures and high local temperatures, which potentially damage the bacteria - it is known from previous experimental and theoretical studies that the repeating transient collapses of cavitation cloud emit pressure waves of magnitude of several MPa [35]. Although more intense, the cavitation cloud collapses are less frequent than in the case of acoustic cavitation as they occur in the range of up to only a few hundred Hz. Consequently exposing the whole amount of fluid to cavitation is again an issue. Finally the developed cloud cavitation is know as the most aggressive one in terms of vibration, noise and erosion what makes an actual bacteria removal facility difficult and expensive to run.

As the cavitation number

$$\sigma = \frac{p - p_v}{1/2 \rho v^2}, \quad (1)$$

where p is the system pressure, p_v is the vapour pressure, ρ is the liquid density and v is flow velocity, is decreased (as either the system pressure is decreased or the flow velocity is increased), a small cavity will extend and grow longer and longer. It becomes a supercavity as soon as it ceases to close on the cavitator wall but inside the liquid, downstream of the cavitator (in the present case downstream of the Venturi section, fig. 2c). The cavity is made of a mixture of vapor and non-condensable gas and the pressure within it is generally considered as constant in time and uniform throughout the cavity. In the present case the throat of the Venturi section serves as a designed point (a geometrical singularity) to fix the detachment point of the cavity. As the cavity pressure is lower than the surrounding pressure, the balance of inertia and pressure forces gives a curvature oriented towards the cavity. This obliges the liquid to penetrate into the cavity and to form a re-entrant jet (similar to the one in developed

cavitation). In an ideal steady flow, the starting point of the jet should be a stagnation point, but the instability affects the re-entrant jet and the whole closure region. Two main regimes occur and alternate continuously with each other: i) the re-entrant jet actually develops and tends to confine the gas and vapor mixture inside the cavity and ii) there is an emission of limited coherent trains of alternate vortices which take off gas and vapor from the cavity and entrain any excess liquid. Thus the rear part of the cavity alternately plays the role of a valve and a pump. On the whole, the suction or pumping effect is dominant and constitutes the driving phenomenon for vaporization at the cavity interface. Vaporization, which takes place mainly at the front part of the cavity, continuously feeds the cavity with vapor and counterbalances the amount of vapor entrained at the rear. In the wake of the cavity (just downstream of the attached cavity) the flow contains many bubbles which are released from the cavity and appear more or less entrapped in the core of alternate vortices. This region is always highly turbulent [35]. In supercavitating flow the bacteria could be harmed if it is rapidly exposed to a very low pressure (i.e. vapor pressure – approximately 2000 Pa for cold water) as it enters the large cavitation bubble. If one succeeds to create a supercavitating bubble that entrains the whole flow cross-section (that all the fluid undergoes vaporization and condensation), then such cavitation type could prove as the most appropriate one for bacteria destruction. Moreover, as already mentioned, supercavitation is not accompanied by noise, vibration and erosion, which would make the operation of a real facility somewhat easier.

In the present experimental campaign we set out to evaluate the efficiency of removal of *Legionella pneumophila* by three distinctive types of cavitation – the commonly used acoustic cavitation, the aggressive developed hydrodynamic cavitation, where the bacteria would be killed by extreme pressures and temperatures and the supercavitation where the bacteria destruction would result from rapid pressure decrease. In addition, we also tested whether one could destruct the bacteria only by slowly lowering the pressure in the sample to the vapor pressure (and not by the rapid decrease of pressure as it occurs in the supercavitating regime).

As the results of the study suggest it is likely that the removal of the *Legionella pneumophila* is caused by the rapid decrease of the pressure and not by the high pressure and temperature peaks as one would expect. Results of this systematic study importantly contribute to the understanding of the bacteria removal mechanisms and therefore show promising ground for further optimization of a methodology for *Legionella pneumophila* removal by cavitation.

2 Experimental set-up and methods

Experiments were performed at the Laboratory for Water and Turbine Machines at the Faculty of Mechanical Engineering, where cavitation test rigs were made and experiments were performed. Preparation of samples and evaluation of test results took place at the Biomedical Research Group Laboratory at the Faculty of Health Sciences (both at the University of Ljubljana).

2.1 Cavitation test-rigs

Acoustic cavitation was achieved in an ultrasonic bath. Another set-up, operated at different flow conditions was used for generation of both developed hydrodynamic cavitation and supercavitation. Before experiments all test rigs were properly disinfected with peroxide and washed with distilled water to prevent other microorganisms and disinfectants bias test results. Washed distilled water from test rig was tested on presence of other microorganisms. To prevent excessive heat bias the results the temperature was measured in the reservoir (or bath) by the Pt100 type A thermometer with uncertainty of $\pm 0.2\text{K}$. During acoustic and hydrodynamic cavitation temperature increased for not more than 15°C , and was always held under 30°C – since the sample exposure time to higher temperature was short

it could not significantly influence the results.

2.1.1 Acoustic cavitation test-rig

A small, 140 mm high and 72 mm in diameter, cylindrical vessel made out of stainless steel, was used for the experiments. A 100 W, 33 kHz piezo actuator was used to generate cavitation. As shown schematically in Figs. 2 and 3, cavitation bubbles appear only at the antinodes of the standing waves – for the present test configuration these lie at levels approximately 22 mm apart [37]. Sufficient fluid mixing is achieved through asymmetrical installation of the actuator. To maintain a constant temperature during the length of the experiment the vessel was put into a cooling chamber – this way the temperature did not rise above 30 °C a level at which the bacteria reproduction would significantly change (increase). Temperature was measured throughout the length of the experiment.

2.1.2 Hydrodynamic cavitation test-rig

The hydrodynamic cavitation test rig shown in Fig. 3, consists of a 2 l reservoir, heat exchanger, pump and a symmetrical Venturi section. Cavitation extent (cavitation number σ , which was mentioned previously – Eqn. 1) can be adjusted by either varying the flow velocity (rotational frequency of the pump) or the system pressure, which is adjusted in the partially filled reservoir connected to either a compressor or a vacuum pump (a range between 0.1 bar and 6 bar is available). The system pressure p was measured in the reservoir, upstream of the Venturi section by the Hygrosens DRTR-AL-10V-R16B pressure probe with an uncertainty of $\pm 0.2\%$. As mentioned the flow rate is adjusted by the rotational frequency of the pump and is measured by the Buerkert SE32 flow meter, with an uncertainty of $\pm 1\%$ (velocities up to 30 m/s can be achieved in the throat of the Venturi section). As already mentioned the temperature of water was constantly monitored by PT100 A type resistance thermometer with an uncertainty of ± 0.2 K. A heat exchanger was installed to maintain the water temperature below 30 °C. The combined uncertainty of setting the operating point (cavitation number) was estimated to 2.5%, what still assures repeatable measurements.

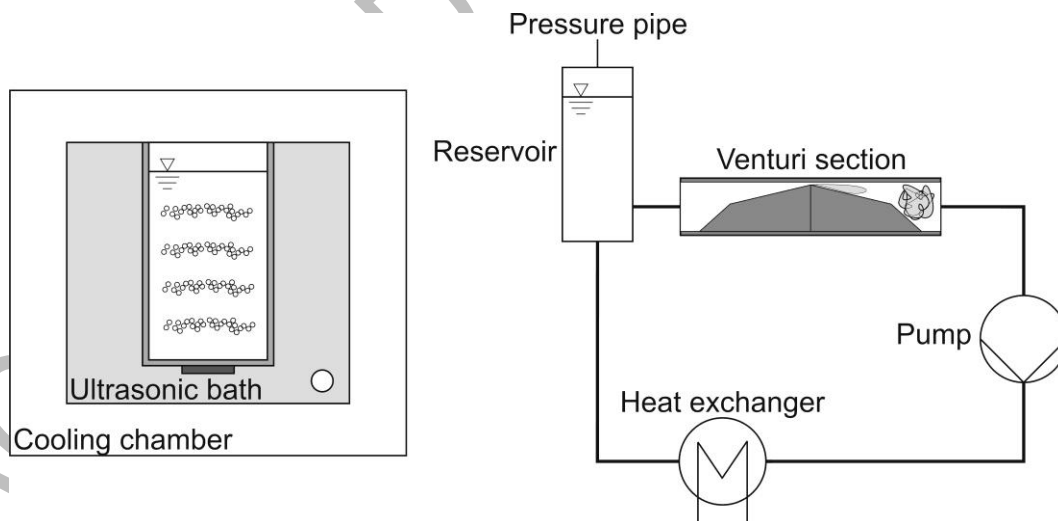

Figure 3: Set-ups for acoustic cavitation (left) and for the developed hydrodynamic cavitation and supercavitation (right).

The present Venturi section is designed to be used in a laboratory environment. The geometry of the Venturi section (Fig. 4) was chosen based on our previous experience. Its design enables the basic condition that different types of cavitation can manifest in it (namely developed cavitation and supercavitation). This is important for the analysis of the effects of the cavitation type on the pollutants

(bacteria, algae, pharmaceuticals, viruses), as the changing of the geometry could significantly alter the flow field and consequently influence the results.

The width of the section is constant at 5mm. At the throat the cross-section is 1x5mm. The divergence angle of 10° was chosen on the fact that unsteady cavitation forms optimally at this value [38]. The secondary divergence angle of 30° downstream was chosen to enable the appearance of stable supercavitation, which needs more room to form. The section was made out of acrylic glass what also enabled the observation of cavitation.

From the eradication (pollutant removal) standpoint of view the design is likely not optimal and further work is planned to design a scaled (pilot size) device, which could be used in real environment (see also [24]).

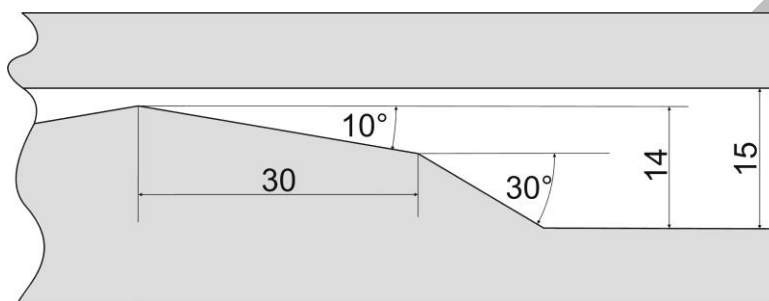

Figure 4: The geometry of the Venturi section.

For the case of developed hydrodynamic cavitation the upstream pressure was held at 5 bar and the velocity at the throat of the Venturi was 27.6 m/s (cavitation number $\sigma=1.30$). To achieve stable supercavitation, both the upstream pressure and the flow velocity needed to be reduced to 0.2 bar and 6.7 m/s, respectively (cavitation number $\sigma=0.75$).

2.2 Sample preparation

We used a standard strain of bacteria *Legionella pneumophila*, subsp. *Pneumophila* ATCC 33153, which was acquired from Czech Collection of Microorganisms (CCM). The sample was prepared a day before the test. One colony forming unit of *Legionella pneumophila* was put in to liquid medium, made from distilled water, yeast extract and cysteine. Then sample was incubating at 36°C for 24 hours. After incubation, test sample was diluted to 4 x 1 l of saline solution to which 1 ml of culture was added. Test samples were properly stored before experiment, to prevent temperature or UV rays effect the concentration of *Legionella pneumophila*.

2.3 Measurements of removal of *Legionella pneumophila*

For a reference measurement 100 ml of the test sample was removed and contained in sterile cup. The rest of the sample was exposed to cavitation. Then again 100 ml was removed for microbiological analysis. The rest of the sample was rejected after each experiment.

Measurements according to ISO 11731:1998 [39] standard were employed for enumeration of *Legionella pneumophila* organisms. Since the method is suitable for waters with prospected low numbers of *Legionella pneumophila* we first diluted the sample up to 10^{-5} . 1 ml of diluted sample was spread onto BCYE agar and left to incubate at $36 \pm 1^\circ\text{C}$. BCYE agar - Buffered charcoal yeast extract (BCYE) agar is a selective growth medium used to culture or grow certain bacteria, particularly the Gram-negative species *Legionella pneumophila*. To determine the viable bacterial number we counted the bacterial cells, which have grown on the agar after the incubation (Fig. 5). Count of viable cells from

1ml sample gives us estimation of concentration of colony forming units per volume CFU/l (or CFU/ml).

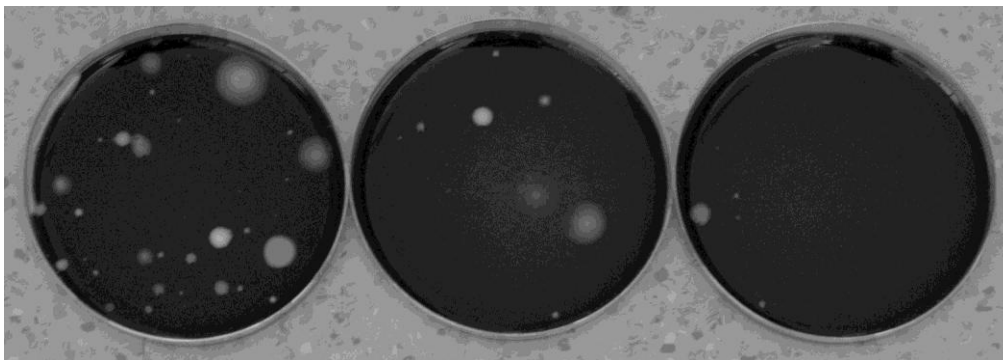

Figure 5: Petri dish culture plates that had been filled with an agar-based medium and had been inoculated with diluted water sample and left to incubate for 48 hours. Unexposed sample (left), sample exposed to supercavitation for 30 min (middle) and for 60 min (right).

3 Results

Since we have had no way of controlling the viable bacterial number in the prepared sample, it varied from 15000 to 180000 CFU/ml. To be able to compare the experiments, the measured values after the treatment (“post”) were normalized by the measured viable bacterial number in the sample that was not exposed to treatment (“pre”):

$$[CFU/ml]_{NORM} = \frac{[CFU/ml]_{post}}{[CFU/ml]_{pre}} \quad (2)$$

No dependency between the removal rate and the initial (untreated sample) number of viable bacteria was found.

3.1 Acoustic cavitation

Three experiments were performed. Two samples were left exposed to cavitation for a period of 50 minutes and one for a period of 1 hour.

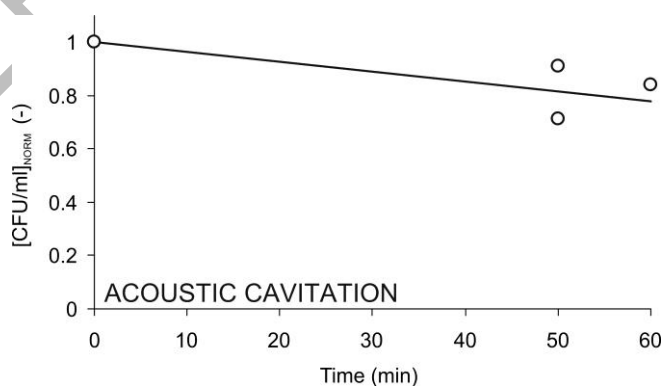

Figure 6: Normalized viable bacterial number for the experiments in acoustic cavitation.

One can see that the number of viable *L. Pneumophila* bacteria reduces only marginally after a relatively long exposure to acoustic cavitation. In average a less than 0.5 % bacteria eradication per minute was achieved.

The result is interesting since acoustic cavitation fails to significantly reduce the bacterial count. This is contradictory to other applications, like pharmaceuticals, where acoustic cavitation performs more efficiently [40].

3.2 Developed hydrodynamic cavitation

Four tests were made where the sample was exposed to developed hydrodynamic cavitation. The exposure time varied from 5 to 48 minutes.

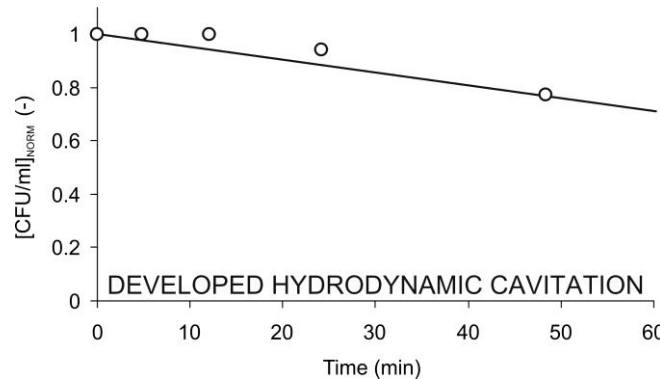

Figure 7: Normalized viable bacterial number for the experiments in developed hydrodynamic cavitation.

For the first 2 measurements, when the sample was cavitated for 5 and 12 minutes, almost no change in viable bacteria number from the initial, unexposed, sample was detected. Only later, after 25 and 48 minutes of exposure, a slight decrease (23 % after 48 minutes) of living bacteria was observed.

3.3 Supercavitation

Finally we tested supercavitating flow regime. 7 samples were exposed to supercavitation. The periods lasted from 7 minutes to 1 hour.

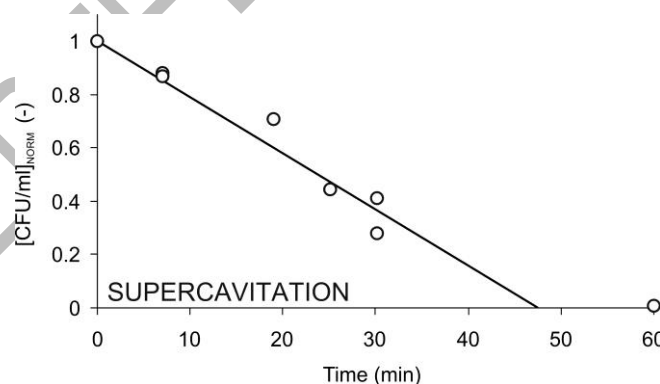

Figure 8: Normalized viable bacterial number for the experiments in supercavitation.

One could observe a considerable decrease of viable bacteria – after 60 minutes the CFU count summed up to only 1.4 % of the initial value. Considering the trend from shorter duration experiments one can expect such an eradication level already after 47 minutes of exposure to cavitation.

A question poses itself whether it is not just the pressure decrease that kills *Legionella pneumophila* and that the same effect could be achieved without cavitation and consequently with less effort. To investigate this possibility we exposed samples to low pressure what is described in the next section.

3.4 Low pressure boiling

A 200 ml water sample was put into a vacuum chamber. The ambient pressure was then slowly lowered to approximately 2500Pa (the vaporization pressure of water at about 22 °C), where the liquid begun to boil. Samples were left boiling for 15 and 30 minutes. The sample temperature did not increase during these tests.

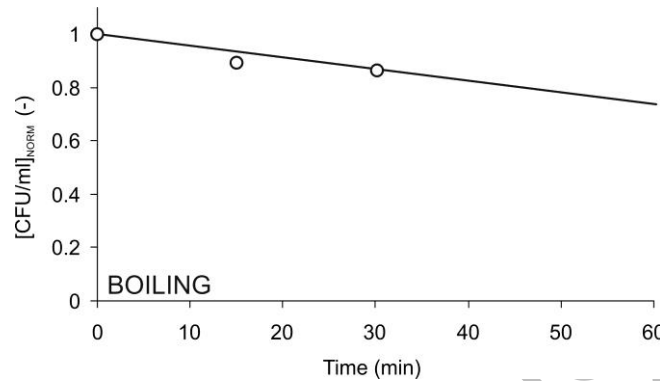

Figure 9: Normalized viable bacterial number for the experiments in low pressure boiling.

Since the purpose of the test was only to support the findings from tests with supercavitation, only two samples were used. Both show that the low pressure only cannot significantly damage the bacteria – it is obvious that the needed condition is the rapid pressure decrease.

4 Discussion

Results imply that a considerable difference in efficiency of bacteria eradication exists between the different types of cavitation. For further analysis the removal rate for each test was calculated as:

$$RR = \frac{\left(\frac{[CFU / ml]_{pre} - [CFU / ml]_{post}}{[CFU / ml]_{pre}} \right) \cdot 100}{\Delta t}, \quad (3)$$

which gives the bacteria removal rate (RR) in terms of %/min. Figure 10 shows a diagram of removal rates (averaged removal rates from each experimental run with corresponding error bars showing the standard deviation) for each cavitation type and the low pressure boiling.

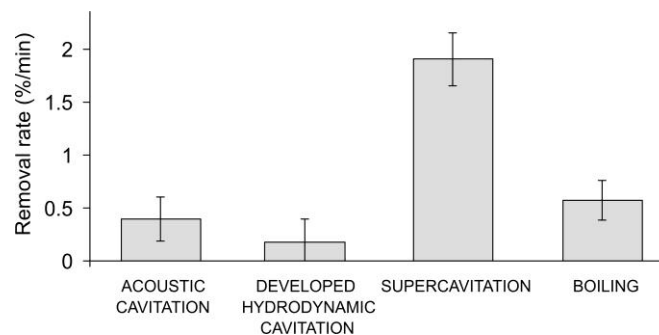

Figure 10: Removal rates for each cavitation type.

To avoid subjective assessment an analysis of variance (ANOVA) of the experiments was performed. It

shows that statistically significant differences exist among 4 sets of measurements along the bacteria removal rate at a confidence level higher than 99.9% (statistical significance level $\alpha < 0.001$). This undoubtedly confirms our reasoning that the bacteria removal rate in sample exposed to supercavitation is much higher than in other types of cavitation.

The fact that the low pressure boiling performed better than either acoustic or developed hydrodynamic cavitation implies that it is the pressure decrease that damages the bacteria – in both acoustic or developed hydrodynamic cavitation we are predominantly dealing with pressure shocks which are emitted at single bubble and bubble cloud collapses. When this pressure decrease is at the same time very rapid (like in the case of supercavitation), the efficiency of eradication grows to a possibly “useful application” level.

The physics behind the eradication of bacteria by supercavitation seems similar to cell disruption by nitrogen decompression [41]. The supercavity extends from the throat of the Venturi to the end of the section and engulfs the whole volume (Fig. 2c). Consequently as the flow passes the throat of the Venturi it enters the cavity - the pressure drop at the transition from the liquid to vapour phase is almost instantaneous (in other words the liquid instantaneously evaporates). This very rapid pressure decrease from roughly 5 bar to 3000Pa disrupts the bacteria, which likely burst. The rapid pressure increase at the closure of the cavity downstream (about 1 ms later), where the flow again condensates may play additional role in bacterial disruption. Finally, when one compares the treated volume, in the case of supercavitation, the treated volume is greater and the method can operate continuously rather than in batch mode, hence it is applicable for “real” water treatment procedures. The mutual action of all three effects: i) rapid pressure decrease, ii) rapid pressure increase and iii) exposure of all the volume to the tension forces explains the promising results of *Legionella pneumophila* treatment by supercavitation.

It makes sense to compare the two competing types of cavitation – the developed hydrodynamic cavitation and supercavitation in terms of passages through the Venturi section. Figure 11 shows the results.

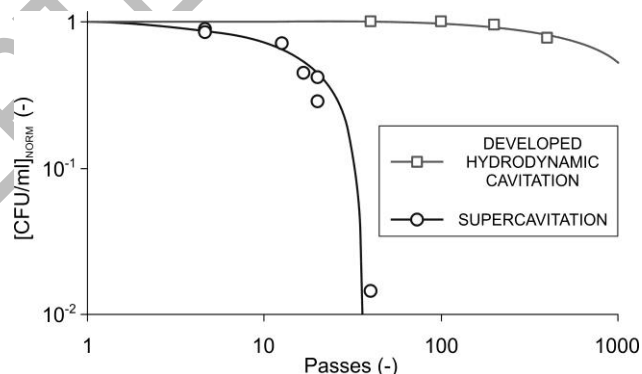

Figure 11: Normalized viable bacterial number for the experiments in developed hydrodynamic cavitation and supercavitation as a function of number of passes through the Venturi.

Again the results point to an inefficiency of the developed hydrodynamic cavitation and at the same time to a clear possibility of using supercavitation for efficient eradication of *Legionella pneumophila* bacteria in water systems. Only about 30 passes through the Venturi section are needed to almost completely remove the bacteria. This can be done within a reasonable amount of time in an average internal water supply system where recirculation of the hot water supply is installed.

4.1 Economic feasibility

Supercavitation is also the only method, which achieved the reduction below 1 log scale. Bolton et al. [32] introduced a figure of merit „Electric energy per order (E_{EO})” - the amount of electric energy required to bring about a reduction by one order of magnitude. The method is best used for situations where concentration is low and independent of the initial concentration (this applies to the present case). E_{EO} value [usual units, kWh/m³/order] can be calculated by [42]:

$$E_{EO} = \frac{P \cdot t}{V \cdot \log_{10} \left(\frac{[CFU/ml]_{pre}}{[CFU/ml]_{post}} \right)}, \quad (4)$$

where P is the rated power [kW] of the system, V is the volume [m³] of water treated in the time t [h]. Higher E_{EO} values correspond to lower removal efficiencies. Table 1 shows the average E_{EO} values and approximate costs for each cavitation type and for conventional treatment of *Legionella Pneumophila* bacteria by thermal shocks.

Table 1: Electric energy per volume and order (E_{EO}) and approximate costs for different treatment techniques.

Technique	E_{EO} (kWh/m ³ /order)	Cost (€/m ³)
Acoustic cavitation	~400	~40
Developed hydrodynamic cavitation	~100	~10
Supercavitation	~1	~0.10
Thermal shock	~30	~3

When one uses the E_{EO} to evaluate the different water treatment approaches the supercavitation clearly stands out. It is, however, still too early to judge whether such a technique is appropriate for installation into an engineered water system as it could lead to, yet unknown, technological problems.

5 Conclusions

In the paper we show a systematic study of *Legionella Pneumophila* bacteria removal by different types of cavitation. We showed that the exposure to supercavitation efficiently eradicates the bacteria, while other techniques (acoustic cavitation, developed hydrodynamic cavitation and low pressure boiling) only marginally reduce the viable bacterial count.

Interestingly the efficiency of the treatment varies significantly between the pollutants. For example developed hydrodynamic cavitation [23, 24] or a combination of both developed hydrodynamic cavitation and acoustic cavitation [22] was found to be the most efficient in pharmaceuticals removal. This could probably be anticipated, as the mechanisms of removal are completely different – in the case of pharmaceuticals we are dealing with increased production of free radicals and consequent oxidation of the compounds. Strangely, though, no study questioned this yet and all researchers simply extrapolate experience from one field to another.

An important issue is whether sonification at a different frequency would improve the eradication efficiency by ultrasonic cavitation. For example theoretical calculations [43] indicate that high quality

resonances in the MHz frequency range are possible for larger (radii greater than 5 μm) Gram positive bacteria. Such a technique may not prove efficient in *Legionella Pneumophila*, a much smaller and Gram negative bacteria with a weak wall, which may not have a distinctive resonance frequency. Hence one can expect that the mechanism of supercavitation or even developed cavitation, where there is a large ensemble of different sized bubbles, with different resonant frequencies, will perform better.

Further work includes an installation of a larger supercavitation body in a pilot test rig and hopefully the development of a supercavitating flow unit in an engineered water system such as warm water distributing system in an apartment building.

Acknowledgment

The authors thank the Slovenian Research Agency which partially financially supported this work under the scope of a project J7-4265.

References

- [1] W.C. Winn, R.L. Myerowitz, The pathology of the Legionella pneumonias, Hum. Pathol., 12 (1981) 401-422.
- [2] D.J. Brenner, J.C. Feeley R.E. Weaver, Family VIII Legionellaceae. In: Bergey's Manual of Systematic Bacteriology, Krieg, N.R., Holt, J.G. (Eds). Williams and Wilkins, Baltimore, MD. (1). 1984, pp. 210-236.
- [3] CDC, Department of Health and Human Services, Centers for Disease Control and Prevention, Public Health Image Library (PHIL), Image ID#. 1187 (2013).
- [4] E. Leoni, P.P. Legnani, M.A. Bucci Sabattini, F. Righi, Prevalence of Legionella spp. In swimming pool environment, Water Res. 35 (2001) 3749-3753.
- [5] O'H.J. Tobin, R.A. Swann, C.R.L Bartlett, Isolation of Legionella pneumophila from water systems: methods and preliminary results, British Medical Journal, 282 (1981) 515-517.
- [6] H. Yamamoto, Y Hashimoto, T. Ezaki, Study of nonculturable Legionella pneumophila cells during multiple-nutrient starvation, FEMS Microbiology Ecology, 20 (1996) 149-154.
- [7] S.M. Katz, J.M. Hammel, The effect of drying, heat, and pH on the survival of Legionella Pneumophila, Ann. Clin. Lab. Sci., 17 (1987) 150-156.
- [8] J. Rogers, A.B. Dowsety, P.J. Dennis, V. Lee, C.V. Keevil, Influence of Plumbing Materials on Biofilm Formation and Growth of Legionella pneumophila in Potable Water Systems, Applied and environmental microbiology, 60(6) (1994), 1842-1851.
- [9] R.M. Wadowsky, R. Wolford, A.M. McNamara, R.B. Yee, Effect of temperature, pH, and oxygen level on the multiplication of naturally occurring Legionella pneumophila in potable water, Appl. Environ. Microbiol., 49 (1985), 1197-1205.
- [10] B.S. Fields, The molecular ecology of legionellae, Trends in Microbiology, 7 (1996) 286-290.
- [11] E.M. Campodonico, C.R. Roy, The Genus Legionella, In Goldman E., Green H.L. (Eds.). Practical

Handbook of Microbiology, CRC Press. 2008, pp. 505-518.

[12] J. Wingender, Hygienically Relevant Microorganisms in Biofilms of Man-Made Water Systems, In: Flemming H.C. Wingender J., Szewzyk U. (Eds). *Biofilm Highlights*. Springer 2011, pp. 189-238.

[13] D.W. Fraser, T.R. Tsai, W. Orenstein, W.E. Parkin, H.J. Beecham, R.G. Sharrar, J. Harris, G.F. Mallison, S.M. Martin, J.E. McDade, C.C. Shepard, P.S. Brachman, Legionnaires' disease: description of an epidemic of pneumonia, *N. Engl. J. Med.*, 297 (1977), 1189-1197.

[14] T.H. Glick, M.B. Gregg, B. Berman, G. Mallison, W.W. Rhodes Jr., I. Kassanoff, An epidemic of unknown etiology in a health department: 1. Clinical and epidemiologic aspects, *Am. J. Epidemiol.*, 107 (1978) 149-160.

[15] B.J. Marston, H.B. Lipman, R.F. Breiman, Surveillance for Legionnaires' disease, *Arch. Intern. Med.*, 154 (1994) 2417-2422.

[16] C.A Joseph, K.D. Ricketts, Legionnaires' diseases in Europe 2007-2008. Surveillance and outbreak reports, *Eurosurveillance*, 15(8) (2010) 2-6.

[17] A. Hojs, A. Petrovič, N. Furlan, Prevention of Legionellosis in public buildings "Preprečevanje legioneloz v javnih objektih", *Zdravstveno varstvo*, 41 (2002) 299-304.

[18] R. Schulze-Röbbecke, M. Rödder, M. Exner, Multiplication and killing temperatures of naturally occurring legionellas, *Zentralbl Bakteriologie Mikrobiologie Hygiene B.*, 184(6) (1987) 495-500.

[19] R.S. Miller, A Review of Common Disinfection Techniques and What ASHRAE Proposed 188P Means to You, *Plumbing Standards* July – September 2012, 12-15.

[20] C. Joseph, J. Lee, J. Wijngaarden van, V. Drasar, M. Castellani-Pastoris, European Guidelines for the control and prevention of travel associated legionnaires' disease, *EWGLI – European Commission* 2005, 66-68.

[21] J.E. Stouth, V.L. Yu., Experiences of the First 16 Hospitals Using Copper-Silver Ionization for Legionella Control; Impact for the Evaluation of other Disinfection Modalities, *Infection Control and Hospital Epidemiology*. 24(8) (2003). 563-568.

[22] P. Braeutigam, M. Franke, R.J. Schneider, A. Lehmann, A. Stolle, B. Ondruschka, Degradation of carbamazepine in environmentally relevant concentrations in water by Hydrodynamic-Acoustic-Cavitation (HAC), *Water Res.*, 46 (2012), 2469-2477.

[23] M. Zupanc, T. Kosjek, M. Petkovšek, M. Dular, B. Kompare, B. Sirok, Ž. Blažeka, E. Heath, Removal of pharmaceuticals from wastewater by biological processes, hydrodynamic cavitation and UV treatment, *Ultrasonics Sonochemistry* 20(4) (2013), 1104-1112.

[24] M. Petkovšek, M. Zupanc, M. Dular, T. Kosjek, E. Heath, B. Kompare, B. Sirok, A rotation generator of hydrodynamic cavitation for water treatment, *Separation and purification technology*, 118 (2013), 415-423.

- [25] M.V. Bagal, P.R. Gogate, Degradation of diclofenac sodium using combined processes based on hydrodynamic cavitation and heterogeneous photocatalysis, *Ultrasonics Sonochemistry*, 21(3) (2014), 1035-1043.
- [26] Y. Xu, J Yang, Y. Wang, F. Liu, J. Jia, The Effects of Jet Cavitation on the Growth of *Microcystis Aeruginosa*, *Journal of Environmental Science and Health - Part A*, 41(10) (2006), 2345-2358.
- [27] P. Li, Y. Song, S. Yu, Removal of *Microcystis aeruginosa* using hydrodynamic cavitation: performance and mechanisms, *Water Research*, 62 (2014), 241-248.
- [28] M. Petkovšek, M. Dular, M. Mlakar, M. Levstek, M. Stražar, B. Širok, A novel rotation generator of hydrodynamic cavitation for waste-activated sludge disintegration, Submitted to *Ultrasonics Sonochemistry* (2014)
- [29] L. Mezule, S. Tsyfansky, V. Yakushevich, T. Juhna, A simple technique for water disinfection with hydrodynamic cavitation: Effect on survival of *Escherichia coli*, *Desalination*, 251 (2010), 152–159.
- [30] S. Arrojo, Y. Benito, A. Martínez Tarifa, A parametrical study of disinfection with hydrodynamic cavitation, *Ultrasonics Sonochemistry*, 15(5) (2008), 903-908.
- [31] G. Loraine, G. Chahine, C.T. Hsiao, J.K. Choi, P. Aley, Disinfection of gram-negative and gram-positive bacteria using DynaJets® hydrodynamic cavitating jets, *Ultrasonics Sonochemistry*, 19(3) (2012), 710–717.
- [32] B. Balasundaram, S.T.L. Harrison, Study of physical and biological factors involved in the disruption of *E. coli* by hydrodynamic cavitation, *Biotechnology Progress*, 22(3) (2006), 907-913.
- [33] W.A. Gaines, B.R. Kim, A.R. Drews, C. Bailey, T. Loch, S. Frenette, D. Koontz, W. Wang, Controlling Cooling Water Quality by Hydrodynamic Cavitation, *Industrial Water Quality* (2007), 538-545.
- [34] M.F. Dadjour, C. Ogino, S. Matsumura, S. Nakamura, N. Shimizu, Disinfection of *Legionella pneumophila* by ultrasonic treatment with TiO₂, *Water Res.*, 40 (2006) 1137-1142.
- [35] J.P. Franc, J.M. Michel, *Fundamentals of Cavitation, Fluid Mechanics and Its Applications* 76, Springer, 2007.
- [36] C. Gong, D.P. Hart, Ultrasound Induced Cavitation and Sonochemical Yields, *Journal of the Acoustical society of America*, 104 (1998), 1-16.
- [37] M. Dular, A. Osterman, Pit clustering in cavitation erosion, *Wear* 265(5/6) (2008), 811-820.
- [38] M. Dular, I. Khelifa, S. Fuzier, M. Adama Maiga, O. Coutier-Delgosha, Scale effect on unsteady cloud cavitation. *Exp. fluids*, 53(5) (2010), 1233-1250.
- [39] ISO, ISO STANDARD 11731:1998 Water quality – Detection and enumeration of *Legionella*, 1998.

[40] P.R. Gogate, A.B. Pandit, Sonochemical reactors: scale up aspects, *Ultrasonics Sonochemistry* 11(3–4) (2004), 105–117.

[41] R.A. Gottlieb, S. Adachi, Nitrogen cavitation for cell disruption to obtain mitochondria from cultured cells, *Methods Enzymol.*, 322 (2000), 213-221.

[42] J.R. Bolton, K.G. Bircher, W. Tumas, C.A. Tolman, Figures-of-merit for the technical development and application of advanced oxidation technologies for both electric- and solar-driven systems (iupac technical report), *Pure Appl. Chem.* 73(4) (2001), 627–637.

[43] P.V. Zinin, J.S. Allen, Deformation of biological cells in the acoustic field of an oscillating bubble, *Physical Review E*, 79 (2009), 021910.

ACCEPTED MANUSCRIPT